

SK301 Vidourle - RF Demodulator

Inputs

Beat-Note Signal

The Beat-Note pattern is provided by the RF-photodetector measuring the power reflected from the optical reference.

Reference Phase

The Reference signal is sent to the mixer's LO-input port. Its phase should be optimized to retrieve the Error signal.

Calibration

This signal can be used instead of the mixer's IF-output during open-loop tests and error calibration.

External Error Offset

This voltage is added to the Error signal. It provides the user with an input for introducing test or compensation signals.

Misc.

DIOs

Reserved for future use.

Config. Switches

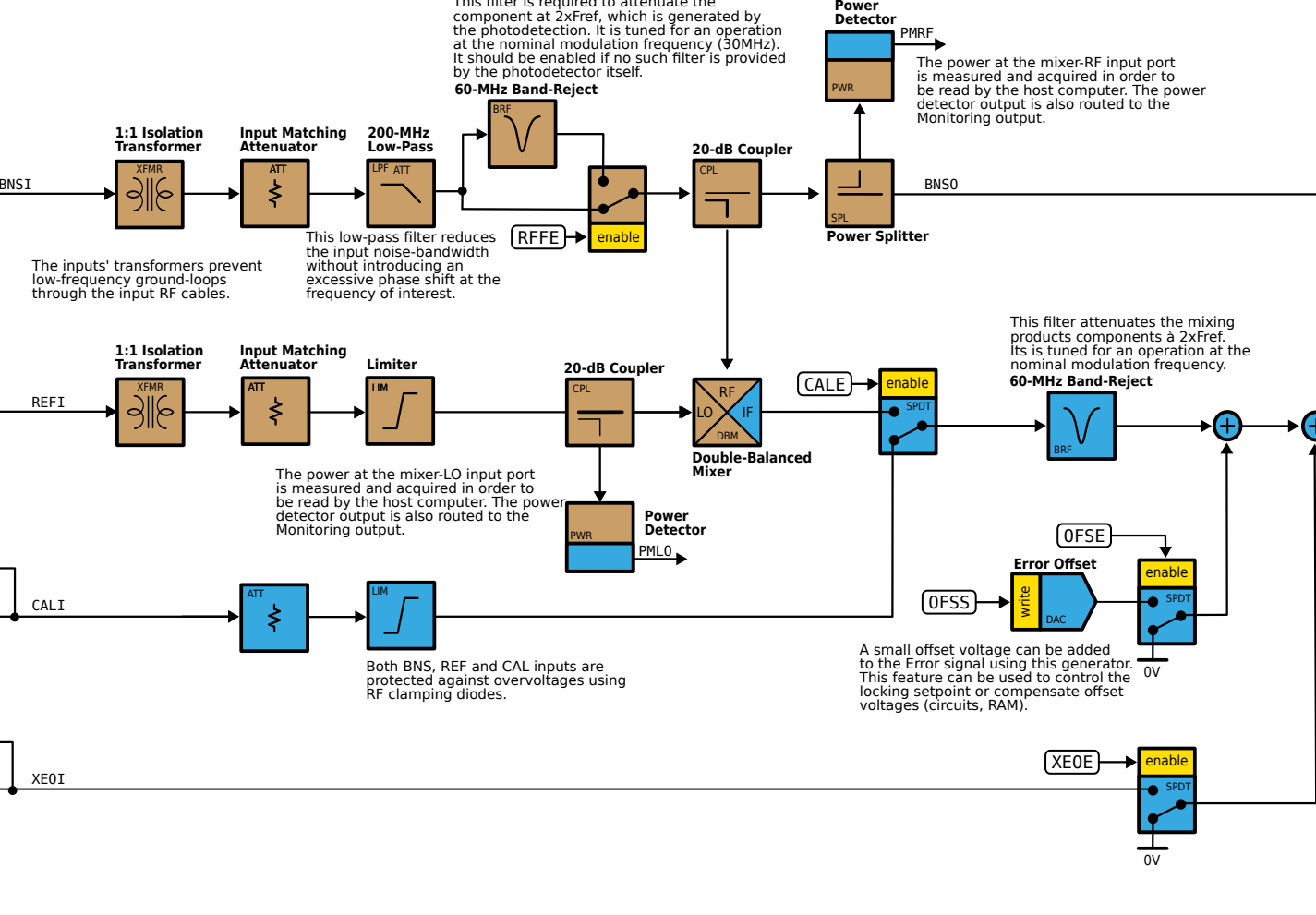

Outputs

Beat-Note Monitor

This signal provides the user with a copy of the beat-note pattern prior its demodulation.

Error

This signal is sent to the servo loop filter.

Monitoring

This output provides the user with copies of the error signal. This output can also be used to measure the powers at the mixer's inputs.

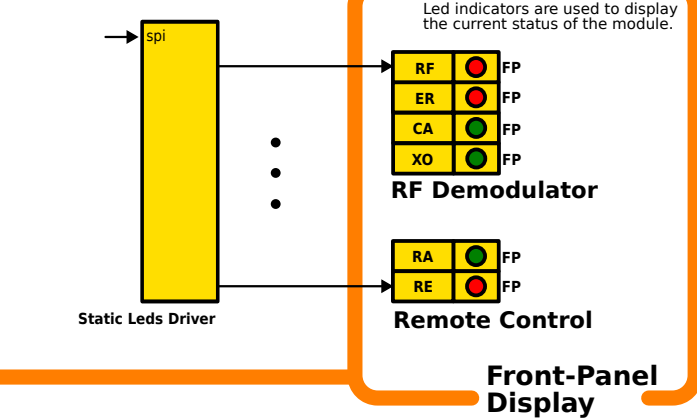
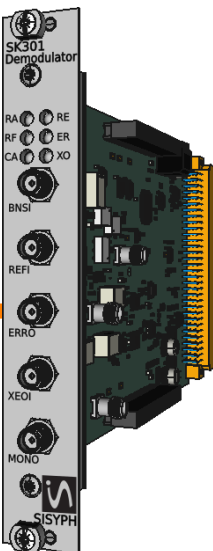
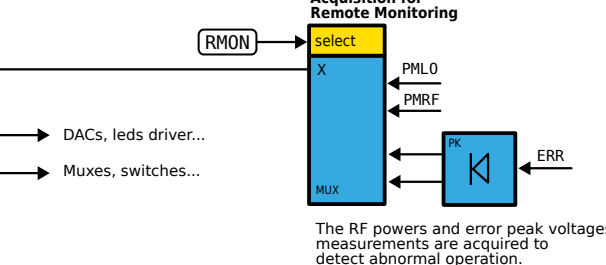
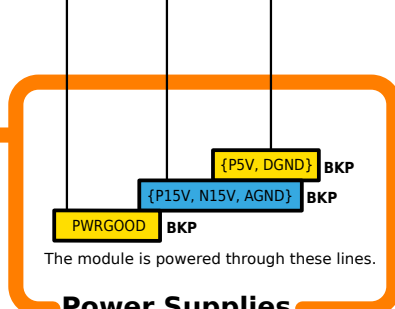
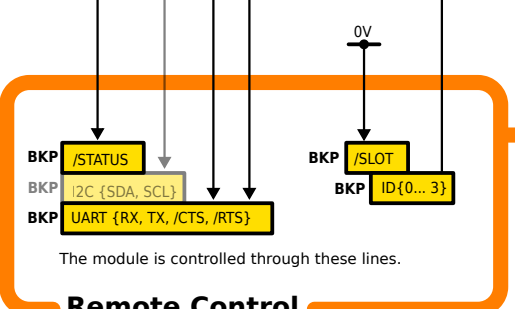
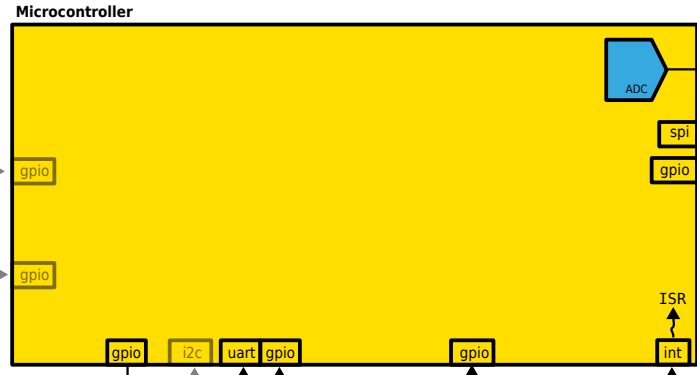

• Only main functionalities are represented. Refer to the *User's Guide* for detailed information.
 • Refer to the *User's Programming Guide* for a complete description of the remote control commands.

Locations	
	Mezzanine board
	PCB Printed circuit board
	BKP Backplane connector
	UTB User's terminal blocks
	EXP Expansion connector
	FP Front panel

Domains	
	Optical
	Digital
	Analog
	HF

Symbols	
	Coaxial connector
	I/O line
	Indicator
	Command
	Jumper

Sheet Size	A3
Sheet No.	1 of 1
APP'D By	
DRN By	GGB
Date	24-03-28
Name	
Date	YY-MM-DD

Signals & Systems for Physics www.sisyph.com		BP91406 31004 TOULOUSE FRANCE
Title/Name SK301 Vidourle - RF Demodulator		Release SK301-R24A
Description Functional block diagram.		
Drawing No. SK301-SG01-P24A		
THIS DOCUMENT IS THE PROPERTY OF SISYPH AND SHALL NOT TO BE REPRODUCED, DISTRIBUTED OR USED WITHOUT PRIOR WRITTEN PERMISSION FROM SISYPH.		